

Industrial PC

MELIPC

MI2012-W User's Manual

-MI2012-W
-MI2012-W-CL

Precautions regarding Warranty

This product was jointly developed and manufactured by Mitsubishi and Advantech Co., Ltd. For the warranty and specifications, pay attention to the following remarks.

<Warranty>

	MI2012-W, MI2012-W-CL
Gratis warranty term	18 months after delivery or 24 months from manufacture
Repair term after discontinuation of production	5 years

- Regarding repair during the warranty period, please confirm the warranty rules of this manual.
- Regarding the repair period after discontinuation of production, there may be cases where it depends on the stock status of maintenance parts.
- It may take some time to respond to the problem or repair the product depending on the condition and timing.

CONDITIONS OF USE FOR THE PRODUCT

- (1). Mitsubishi Electric Industrial PC ("the PRODUCT") shall be used in conditions;
 - i) where any problem, fault or failure occurring in the PRODUCT, if any, shall not lead to any major or serious accident; and
 - ii) where the backup and fail-safe function are systematically or automatically provided outside of the PRODUCT for the case of any problem, fault or failure occurring in the PRODUCT.
- (2). The PRODUCT has been designed and manufactured for the purpose of being used in general industries.

MITSUBISHI SHALL HAVE NO RESPONSIBILITY OR LIABILITY (INCLUDING, BUT NOT LIMITED TO ANY AND ALL RESPONSIBILITY OR LIABILITY BASED ON CONTRACT, WARRANTY, TORT, PRODUCT LIABILITY) FOR ANY INJURY OR DEATH TO PERSONS OR LOSS OR DAMAGE TO PROPERTY CAUSED BY the PRODUCT THAT ARE OPERATED OR USED IN APPLICATION NOT INTENDED OR EXCLUDED BY INSTRUCTIONS, PRECAUTIONS, OR WARNING CONTAINED IN MITSUBISHI'S USER, INSTRUCTION AND/OR SAFETY MANUALS, TECHNICAL BULLETINS AND GUIDELINES FOR the PRODUCT. ("Prohibited Application")

- Nuclear Power Plants and any other power plants operated by Power companies, and/or any other cases in which the public could be affected if any problem or fault occurs in the PRODUCT.
- Railway companies or Public service purposes, and/or any other cases in which establishment of a special quality assurance system is required by the Purchaser or End User.
- Aircraft or Aerospace, Medical applications, Train equipment, transport equipment such as Elevator and Escalator, Incineration and Fuel devices, Vehicles, Manned transportation, Equipment for Recreation and Amusement, and Safety devices, handling of Nuclear or Hazardous Materials or Chemicals, Mining and Drilling, and/or other applications where there is a significant risk of injury to the public or property.



Safety Precautions

(Read these precautions before using this product.)

Before using this product, please read this manual and the relevant manuals carefully and pay full attention to safety to handle the product correctly.

In this manual, the safety precautions are classified into two levels:

" WARNING " and " CAUTION ".

 WARNING	Indicates that incorrect handling may cause hazardous conditions, resulting in death or severe injury.
 CAUTION	Indicates that incorrect handling may cause hazardous conditions, resulting in minor or moderate injury or property damage.

Under some circumstances, failure to observe the precautions given under " CAUTION" may lead to serious consequences.

Observe the precautions of both levels because they are important for personal and system safety.

Make sure that the end users read this manual and then keep the manual in a safe place for future reference.

[Design Precautions]

WARNING

- Configure safety circuits external to the product to ensure that the entire system operates safely even when a fault occurs in the external power supply or the product. Failure to do so may result in an accident due to an incorrect output or malfunction. Emergency stop circuits, protection circuits, and protective interlock circuits for conflicting operations (such as forward/reverse rotations or upper/lower limit positioning) must be configured external to the product.
- Configure a circuit so that the programmable controller is turned on first and then the external power supply. If the external power supply is turned on first, an accident may occur due to an incorrect output or malfunction.
- Before performing operations for the product from the peripheral connected, read the relevant manuals carefully and ensure the safety.

CAUTION

- Do not install the control lines or communication cables together with the main circuit lines or power cables. Keep a distance of 100mm or more between them. Failure to do so may result in malfunction due to noise.
- When selecting fuses and breakers for external circuits, consider the specification values of fusing/ detection characteristics and inrush current.
- When using an uninterruptible power supply (UPS), do not use the one that outputs square waves.

[Transportation Precautions]

CAUTION

- When transporting lithium batteries, follow the transportation regulations. For details on the regulated models, refer to “Precautions for Battery Transportation” in this manual.
-

[Installation Precautions]

CAUTION

- Use the product in an environment that meets “General Specifications” in this manual. Failure to do so may result in electric shock, fire, malfunction, or damage to or deterioration of the product.
 - When using the product in an environment of frequent vibrations, fix the power supply module with a screw.
 - Do not directly touch any conductive parts and electronic components of the product. Doing so can cause malfunction or failure of the product.
-

[Wiring Precautions]

WARNING

- Shut off the external power supply (all phases) used in the system before installation and wiring. Failure to do so may result in electric shock or cause the product to fail or malfunction.
-

CAUTION

- Ground the FG terminal of the product with a ground resistance of 100 ohms or less. Failure to do so may result in electric shock or malfunction.
 - Securely connect the connector of an external device to the product. Poor contact may cause malfunction.
 - Do not install the control lines or communication cables together with the main circuit lines or power cables. Keep a distance of 100mm or more between them. Failure to do so may result in malfunction due to noise.
 - Place the cables in a duct or clamp them. (Cable ties made of nylon can be used as well.) If not, dangling cable may swing or inadvertently be pulled, resulting in damage to the product or cables or malfunction due to poor contact.
 - Check the interface type and correctly connect the cable. Incorrect wiring (connecting the cable to an incorrect interface) may cause failure of the product and external device.
 - Prevent foreign matter such as dust or wire chips from entering the product. Such foreign matter can cause a fire, failure, or malfunction.
 - When disconnecting the cable from the product, do not pull the cable by the cable part. For the cable with connector, hold the connector part of the cable. Pulling the cable connected to the module may result in malfunction or damage to the product or cable.
 - Wiring and replacement of a AC adapter must be performed by qualified maintenance personnel with knowledge of protection against electric shock.
-

[Startup and Maintenance Precautions]

WARNING

- Do not touch any terminal while power is on. Doing so will cause electric shock or malfunction.
 - Correctly connect the battery connector. Do not charge, disassemble, heat, short-circuit, solder, or throw the battery into the fire. Also, do not expose it to liquid or strong shock. Doing so will cause the battery to produce heat, explode, ignite, or leak, resulting in injury and fire.
 - Shut off the external power supply (all phases) used in the system before cleaning the product or retightening the terminal screws, connector screws, or module fixing screws. Failure to do so may result in electric shock.
-

CAUTION

- Do not disassemble or modify the product. Doing so may cause failure, malfunction, injury, or a fire.
 - Use any radio communication device such as a cellular phone or PHS (Personal Handy-phone System) more than 25cm away in all directions from the product. Failure to do so may cause malfunction.
 - Do not drop or apply shock to the battery to be installed in the product.
 - Before handling the product, touch a conducting object such as a grounded metal to discharge the static electricity from the human body. Failure to do so may cause the product to fail or malfunction.
-

[Power-on Precautions]

CAUTION

- Wait for ten seconds or more after power supply shutdown of the product. Then, supply input power again.
-

[Disposal Precautions]

CAUTION

- When disposing of this product, treat it as industrial waste.
 - When disposing of batteries, separate them from other wastes according to the local regulations. For details on battery regulations in EU member states, refer to “Handling of Batteries and Devices with Built-In Batteries in EU Member States” in this manual.
-

Safety Precautions

Avant d'utiliser ce produit, lire attentivement ce manuel ainsi que les manuels auxquels il renvoie, et toujours considérer la sécurité comme de la plus haute importance en manipulant le produit correctement.

Dans ce manuel, les précautions de sécurité sont classées en deux niveaux, à savoir :

"**⚠**AVERTISSEMENT" et "**⚠**ATTENTION".

⚠ AVERTISSEMENT	Attire l'attention sur le fait qu'une négligence peut créer une situation de danger avec risque de mort ou de blessures graves.
⚠ ATTENTION	Attire l'attention sur le fait qu'une négligence peut créer une situation de danger avec risque de blessures légères ou de gravité moyennes ou risque de dégâts matériels.

Dans certaines circonstances, le non-respect d'une précaution de sécurité introduite sous le titre "**⚠**ATTENTION" peut avoir des conséquences graves.

Les précautions de ces deux niveaux doivent être observées dans leur intégralité car elles ont trait à la sécurité des personnes et aussi du système.

Veiller à ce que les utilisateurs finaux lisent ce manuel qui doit être conservé soigneusement à portée de main pour s'y référer autant que de besoin.

[Précautions lors de la conception]

⚠AVERTISSEMENT

- Configurer des circuits de sécurité extérieurs à le produit pour garantir la sécurité du système dans son ensemble à la survenance d'une anomalie dans l'alimentation externe comme dans le produit. Faute de quoi, une instruction de sortie incorrecte ou un dysfonctionnement pourrait être à l'origine d'un accident. Configurer des circuits de sécurité externes, comme un circuit d'arrêt d'urgence, un circuit de protection et les circuits de verrouillage de sécurité pour l'opération d'inversion de marche avant/arrière et de positionnement en limite haute/basse.
- Configurer le circuit de façon à allumer d'abord le produit avant l'alimentation externe. Si on commence par brancher l'alimentation externe, ceci peut être une cause d'accident en cas de sortie incorrecte ou autre dysfonctionnement.
- Veuillez lire attentivement le manuel de l'appareil connecté et vérifier entièrement la sécurité lors de la connexion du périphérique à le produit et de son fonctionnement.

⚠ATTENTION

- Ne pas entremêler les lignes de commandes ou câbles de communication avec les lignes des circuits principaux ou les câbles d'alimentation. Les installer en maintenant entre eux une distance minimum de 100 mm. Faute de quoi, il y a risque de dysfonctionnement par un bruit.
- Lorsque vous sélectionnez des fusibles et des disjoncteurs pour des circuits externes, tenez compte des valeurs de spécification des caractéristiques de fusion / détection et du courant d'appel.
- Lorsque vous utilisez un onduleur, n'utilisez pas celui qui émet des ondes carrées.

[Précautions de transport]

⚠ATTENTION

- Pour le transport des piles au lithium, respecter la réglementation afférente à ce transport. Pour le détail des modèles soumis à une réglementation, voir le "Précautions for Battery Transportation" de ce manuel.

[Précautions d'installation]

⚠ ATTENTION

- *Utiliser le produit dans un environnement en conformité avec les "1.2.1 GENERAL" de ce manuel. Faute de quoi, il a risque d'électrocution, de départ de feu, de dysfonctionnement, d'endommagement ou de détérioration du produit.*
 - *Si le produit est installé dans un environnement exposé aux vibrations, le produit doit être immobilisé par une vis de blocage.*
 - *Éviter tout contact direct avec les parties conductrices et les composants électroniques du produit ou des connecteurs. Cela pourrait être à l'origine d'un dysfonctionnement ou d'une panne du produit.*
-

[Précautions de câblage]

⚠ AVERTISSEMENT

- *Couper l'alimentation externe du système (sur toutes les phases) avant l'installation et le câblage. Faute de quoi, il y a risque d'électrocution et d'endommagement du produit.*
-

⚠ ATTENTION

- *Mettre à la terre la borne FG du produit avec une résistance de terre inférieure à 100 ohms. Faute de quoi, il y a risque d'électrocution et de dysfonctionnement.*
 - *Raccorder fermement le connecteur sur le produit. Tout mauvais contact peut être source de dysfonctionnements.*
 - *Ne pas entremêler les lignes de commandes ou câbles de communication avec les lignes des circuits principaux ou les câbles d'alimentation. Les installer en maintenant entre eux une distance minimum de 100 mm. Faute de quoi, il y a risque de dysfonctionnement par un bruit.*
 - *Les câbles doivent être placés dans un conduit de câbles ou doivent être attachés. Faute de quoi, le ballonnement ou le déplacement des câbles pourrait endommager le module ou les câbles et être à l'origine de dysfonctionnements par mauvais contact. Ne pas serrer les câbles de rallonge en retirant la gaine de câble.*
 - *Vérifier le type d'interface et raccorder les câbles correctement. Un câblage incorrect (avec raccordement d'un câble à une interface incorrect) peut entraîner une panne du produit ou du dispositif externe.*
 - *Veiller à ne pas laisser la poussière, les copeaux métalliques ou d'autres corps étrangers pénétrer dans le produit. De telles corps étrangers peuvent être à l'origine d'un départ de feu, d'une panne ou d'un dysfonctionnement.*
 - *Pour débrancher le câble du produit, ne tirer directement sur le câble proprement dit. Pour les câbles avec connecteur, saisir le câble par le connecteur. Tirer sur un câble raccordé au produit peut endommager le câble ou le produit et être à l'origine de dysfonctionnements.*
 - *Le câblage et le remplacement d'un produit d'alimentation doivent être effectués par un personnel de maintenance qualifié et formé à la protection contre les risques d'électrocution.*
-

[Précautions de mise sous tension]

⚠ ATTENTION

- *Attendez dix secondes ou plus après l'arrêt de l'alimentation électrique du produit. Ensuite, alimentez à nouveau le courant d'entrée.*
-

[PRÉCAUTIONS DE MISE EN SERVICE ET DE MAINTENANCE]

⚠ AVERTISSEMENT

- *Ne toucher à aucun des bornes quand le système est sous tension. Faute de quoi, il y a risque d'électrocutions et de dysfonctionnements.*
 - *Raccorder correctement le connecteur des piles. Les piles ne doivent pas être rechargées, démontées, court-circuitées ou soudées. Elles ne doivent pas non plus être jetées au feu. De plus, ne pas les exposer à des liquides ou à des chocs violents. Cela pourrait entraîner une surchauffe ou un éclatement de la pile qui pourrait s'enflammer et être à l'origine de blessures ou d'un départ de feu.*
 - *Couper l'alimentation externe utilisée pour le système (sur toutes les phases) avant de procéder au nettoyage du module ou au resserrage des vis de bornes des vis de connecteur ou des vis de fixation du module. Faute de quoi, il y a risque d'électrocution et le produit risque de tomber en panne ou de mal fonctionner.*
-

⚠ ATTENTION

- *Ne pas démonter ni modifier le produit. Cela pourrait entraîner des pannes ou dysfonctionnements et être à l'origine de blessures ou de départs de feu.*
 - *Tout type d'appareil de communication radio, y compris les téléphones portables et les appareils PHS (Personal handy-phone system), doit être tenus éloignés de plus de 25 cm de le produit, dans tous les sens. Le non-respect de cette précaution expose à des dysfonctionnements.*
 - *Ne pas faire tomber ou soumettre à de forts chocs les piles à installer dans les modules.*
 - *Avant de manipuler un produit, se débarrasser de la charge électrostatique qu'accumule le corps humain en touchant un objet conducteur approprié. Le non-respect de cette précaution peut être à l'origine de pannes ou de dysfonctionnements du produit.*
-

[Précautions de mise sous tension]

⚠ ATTENTION

- *Attendez dix secondes ou plus après l'arrêt de l'alimentation électrique du produit. Ensuite, alimentez à nouveau le courant d'entrée.*
-

[Précautions de mise au rebut]

⚠ ATTENTION

- *Lors de sa mise au rebut, ce produit doit être traité comme un déchet industriel.*
 - *Les piles ou batteries doivent être mises au rebut séparément des autres déchets et conformément à la réglementation locale. Pour le détail des règlements sur les piles et batteries dans les pays membres de l'Union Européenne, voir le "Handling of Batteries and Devices with Built-In Batteries in EU Member States" de ce manual.*
-

PRECAUTIONS FOR USING THE PRODUCT

[Precautions for the product manufactured by Microsoft® Corporation]

The product is equipped with Windows® 10 IoT Enterprise manufactured by Microsoft Corporation in the United States as OS.

For using this product, our company does not have any responsibility for a problem and the damage caused by the product manufactured by Microsoft Corporation in the United States.

For a problem and specifications of the product manufactured by Microsoft Corporation in the United States, refer to the manual for the product manufactured by Microsoft Corporation in the United States or contact with Microsoft Corporation.

Contents

Chapter 1	Overview	1
1.1	Introduction	2
1.2	Hardware Specifications	2
1.2.1	General	2
1.3	System Hardware	3
1.3.1	I/O Interfaces	3
1.3.2	Environment	4
1.4	Chassis Dimensions	5
1.5	Accessories	5
Chapter 2	Hardware Functionality	7
2.1	Introduction	8
2.2	Serial Interface (COM1/COM2)	9
2.2.1	RS-232/422/485 Interface (COM1 & COM2)	9
2.2.2	To switch the internal SW1/SW2/SW3 according to the placement	10
2.3	LAN: Ethernet Connector	11
2.4	Power Connector	11
2.5	USB Connector	11
2.6	Display Connector	12
2.7	RTC Battery	13
2.8	Power Button/Power Management	13
2.8.1	Power mode switch	13
2.9	mPCIe Card Socket	14
2.9.1	iDoor Expansion Slot	14
2.10	PCIe/PCI Slot	14
2.11	SATA HDD/SSD Drive	15
2.12	Audio Jack	15
2.13	LED Indicators	15

Chapter 3	Initial Setup	17
3.1	Connecting Power.....	18
3.2	Inserting an iDoor Module.....	18
3.3	Installing a Hard Disk	20
3.4	Installing an Interface Card or CFast Card	21
3.5	Mounting MI2012-W.....	22
3.6	Battery Replacement.....	24
3.7	Windows update settings	25
3.8	Troubleshooting	26
3.9	Cautions when repairing the product	27
Appendix A	System Settings and Pin Assignments	29
A.1	System I/O Address and Interrupt Assignment.....	30
A.2	Board Connectors and Switches.....	31
A.3	Function of connectors and switches.....	32
A.4	Audio (Pin header)	33
A.5	COM1/COM2	34
A.6	Power Connector (PWR)	35
A.7	SW4 Power Switch.....	36
A.8	CN19/CN20 mPCIe.....	37
A.9	CN20 mSATA.....	39
A.10	VO1 reserved for power output.....	41
A.11	CN1 internal power supply 12V for PCI/PCIe	42
Appendix B	Recovery.....	43
B.1	Creating Recovery Media	44
B.2	BIOS Setting Change.....	44
B.3	Recovery	45
B.4	Pre-installation Software	45
Appendix C	Regulation and Standard	47
C.1	RoHS information.....	48
C.2	EMC and low voltage directives	49
C.3	Handing of Batteries and Devices with Built-in Batteries In EU Member States.....	51
C.4	Precautions for Battery Transportation	52
C.5	Statement for electromagnetic Interference.....	53
WARRANTY	54
REVISIONS	55
TRADEMARKS	55

Chapter 1

Overview

This chapter provides an overview of MI2012-W specifications.

Sections include:

- Introduction
- Hardware specification
- System Hardware
- Chassis dimensions
- Accessories

1.1 Introduction

MI2012-W (※) integrates high-performance Intel 6th gen Dual Core i3 processor and QM170 chip set, provided with three expansion slot at maximum, including PCI/PCIe slot and iDoor expansion slot, added with two-system display output, 6-port USB 3.0, and mPCIe socket.

Using iDoor technology, the product supports various expansion functions for automation such as industry field bus communication, PoE, COM, and digital I/O. MI2012-W is equipped with the hot-swap supporting HDD/SSD slot with drop-preventing screws, and only requires RTC battery for replacement for easy maintenance.

(※) After that, it includes MI2012-W-CL unless otherwise noted.

1.2 Hardware Specifications

1.2.1 General

- Dimensions (W×D×H):
 - MI2012-W: 142 x 238 x 177 mm (5.6" x 9.3" x 6.9")
- Mounting: Wall mount, Stand mount, Enclosure mount
- Power Consumption: 30 W (Typical, no card added)
Power mode: 10Vdc-36Vdc, support AT/ATX power mode BIOS AT simulation mode (support system reboot automatically after power recovery)
 - ※ Be sure to use the designated AC adapter supplied.
 - ※ When using MI2012-W-CL, prepare an AC cable that satisfies the following specifications.

Connector shape	: IEC 60230-1 C13
Plug shape	: It conforms to the plug shape of the country of use.
Compliance standard	: It conforms to the safety standard of the country of use
Rating	: It must be not less than the voltage and current value to be used
Cable length	: Cable length shall be length to allow voltage drop
- Weight: 3.9 kg
- Installed OS: Windows10 IoT Enterprise 2016 LTSC
- Cooling method: Fanless

1.3 System Hardware

- CPU : Intel Core® i3-6102E (3M Cache,1.9GHz)
- Memory: 8G DDR4 built-in
- Indicators: LEDs for Power, Battery, HDD, COM (Tx/Rx)
- Storage: 2 × 2.5" SATA HDD/SSD bays, support 9.5mm height & SATA Gen3.0, 1 x mSATA slot, 1 x CFAST slot *1
- Watchdog Timer: 256 levels time interval, programmable from 0 to 255 sec
- Expansion Slots: 2×Full-size mPCIe, 1× PCIe16, 1× PCIe1
- PCIe max speed : 5GT/s ; PCI max speed : 66MHz ;
- Each PCI/PCIe slot can support below power rail:*2

Slot type	A: 3.3V	B: 5V	C: 12V	D: -12V	Note
PCI slot	typical 3.03A Max 6.06A	typical 2A Max 4A	typical 0.83A Max 1.66A	Max 0.5A	A+B+C+D, total power <20W
PCIe slot	typical 3.03A Max 6.06A	typical 2A Max 4A	typical 0.83A Max 1.66A	N/A	A+B+C, total power <20W

- Note! *1 When attaching SATA HDD/SSD, use the product whose operation guaranteed temperature of HDD, SSD is 85 °C or more as an upper limit.
-  *2 Total power consumption combined on PCI and PCIe slots should be less than 40 Watt.

1.3.1 I/O Interfaces

- Serial Ports: 2× RS-232/422/485 (DB9, auto flow control, 50 ~ 115.2 kbps)
- LAN Ports: 2× RJ45 (10/100/1000 Mbps IEEE 802.3u 1000Base-T Fast Ethernet)
- USB Ports: 6× USB 3.0 Ports
- Displays: 1 x HDMI (1920 x 1080 @ 24 Hz 24 bpp supported), 1 x DVI-I (1920 x 1080 @ 60 Hz 24 bpp supported), dual display supported
- Power Connector: 3-pin (terminal block)

1.3.2 Environment

- Relative Humidity: 10~90% (Non-condensing)
- Operating Temperature: 0 to 55 °C (32 to 131 °F)
(Safety certification: 0 to 45 °C (32 to 113°F))
- Storage Temperature: -40 to 75 °C (40 to 167 °F)
- Shock Protection:
 - IEC 60068-2-27
 - 50 G, half sine, 11 ms
- Vibration Protection:
 - IEC 60068-2-64 (Random 1 Oct./min, 1hr/axis.)
 - 1.5 G rms @ 5 ~ 500 Hz with HDD
 - 4G rms @ 5 ~ 500 Hz with SSD

1.4 Chassis Dimensions

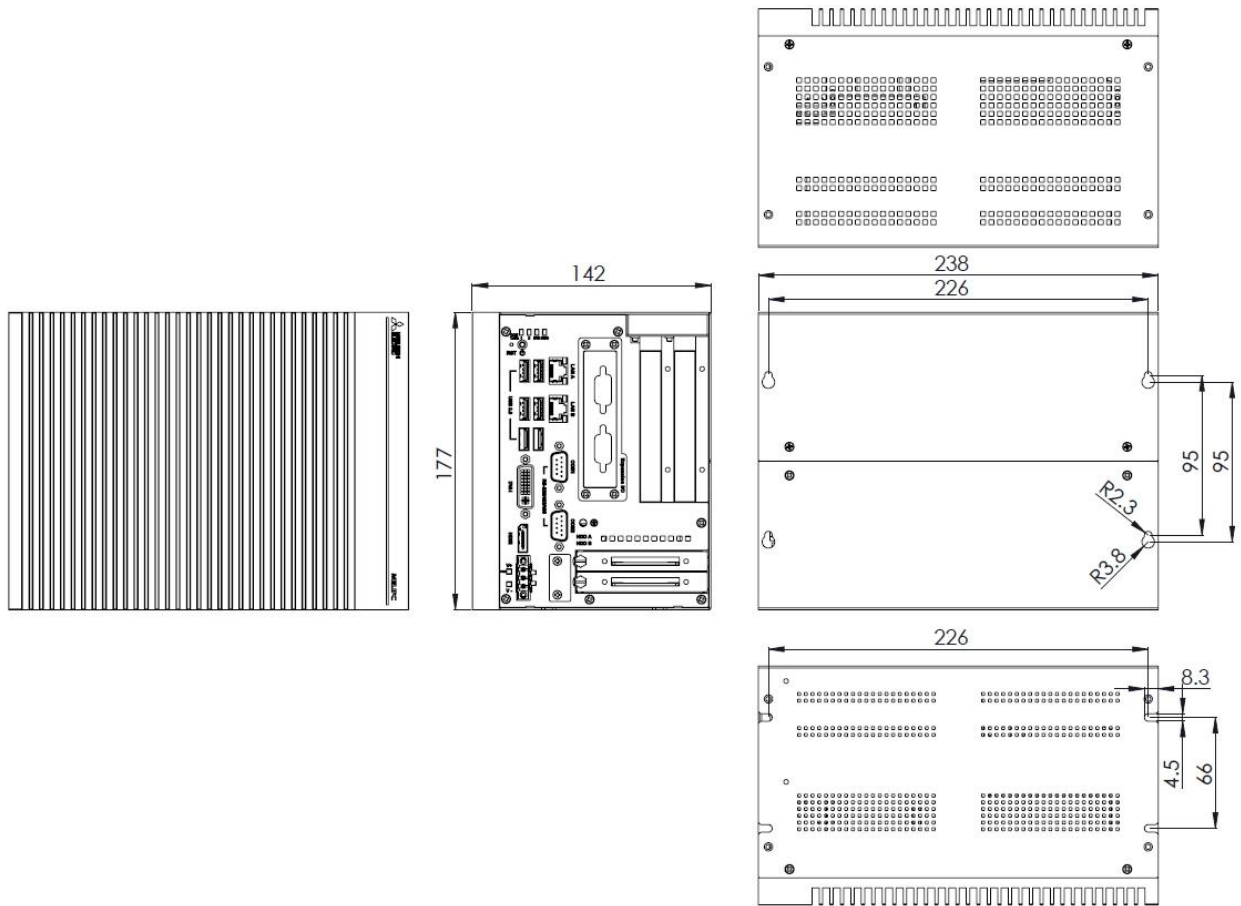

Figure 1.1 MI2012-W Dimensions

1.5 Accessories

- Designated AC adapter: 1 pc
- Power cord(Only MI2012-W): 1 pc
- 3-pin plug-in block for AC adapter connection: 1 pc
- DVI-VGA connector: 1 pc
- Wall-mount kit: 2 pcs
- M3*5L screws for fastening wall mount kit and HDD/SSD: 12 pcs
- Screws for fastening mPCIe modules: 4 pcs
- Manual: 1 copy
- Restriction of the Use of Certain Hazardous Substances in Electrical Equipment by Chinese RoHS: 1 copy
- License Agreement for Edgexross basic software: 1 copy
- License Agreement for SLMP data collector: 1 copy
- Software License Agreement for SLMP data collector: 1 copy

Chapter 2

Hardware Functionality

This chapter shows how to setup MI2012-W hardware functions, including connecting peripherals, setting switches and indicators.

Sections include:

- Introduction
- Serial Interface
- LAN: Ethernet Connector
- Power Connector
- USB Connector
- Display Connector
- RTC Battery
- Power Button/Power Control
- mPCIe Card Socket
- PCIe/PCI Slot
- SATA HDD/SSD Drive
- Audio Jack
- LED Indicators

2.1 Introduction

The below drawing shows the interface of the product.

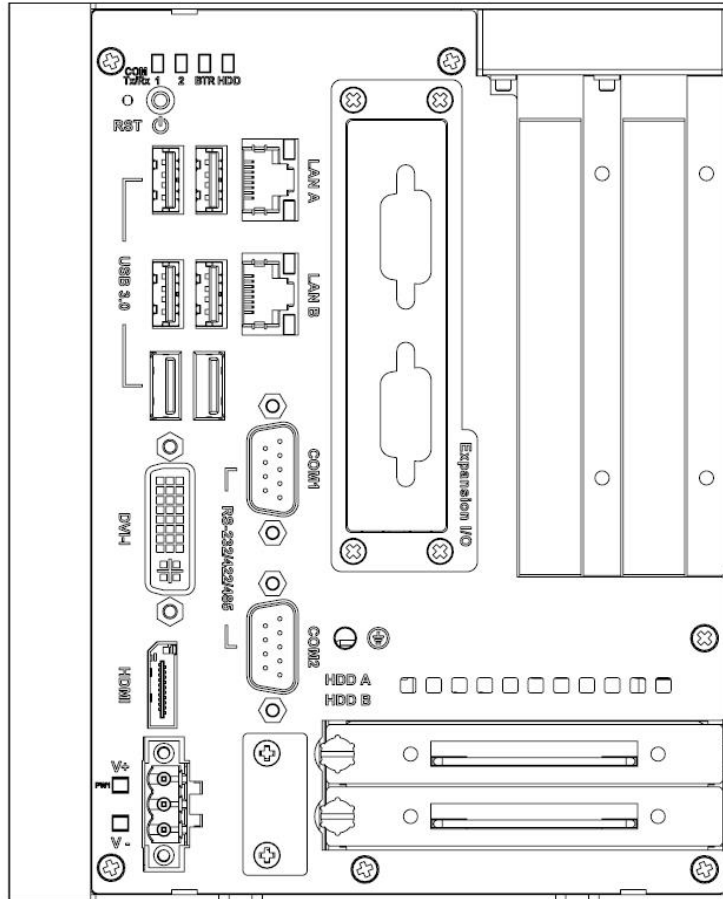

Figure 2.1 MI2012-W (Front View)

2.2 Serial Interface (COM1/COM2)

The product is provided with two standard RS-232/422/485 serial communication interface ports:

The IRQ and I/O address of serial ports are listed as below.

COM1 (Pin header CN3)

COM2 (Pin header CN4)

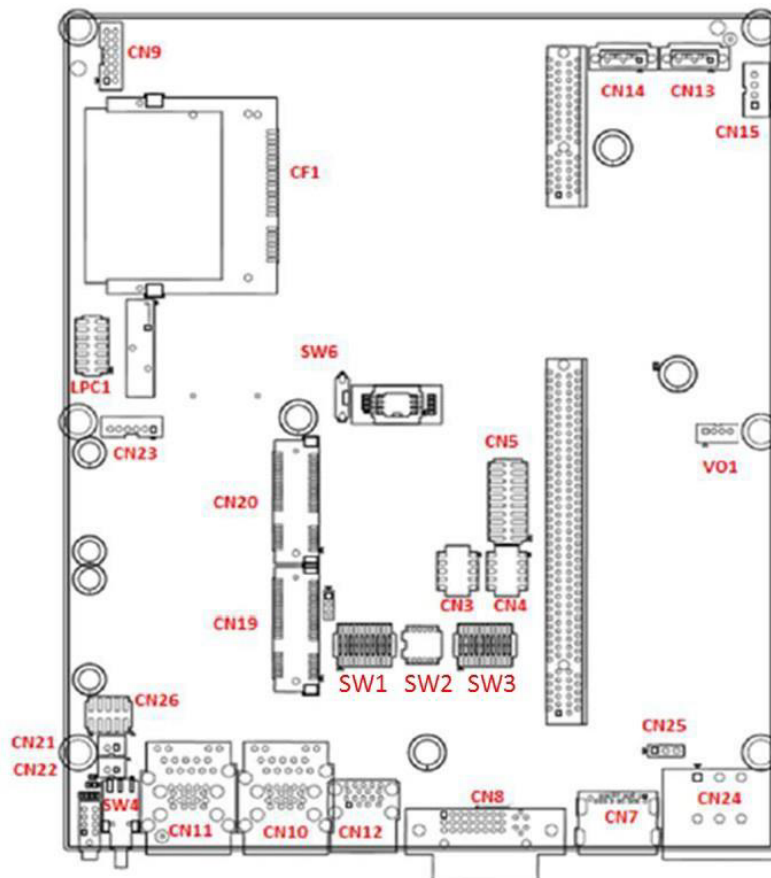

Figure 2.2 Serial Interface (COM1, COM2)

2.2.1 RS-232/422/485 Interface (COM1 & COM2)

The product offers two serial communication interface port.

- SW1 for COM1(RS-232/422/485) switch
- SW2 for RS485/422 receiver termination setting
- SW3 for COM2(RS-232/422/485) switch

The serial port is set to "RS422 slave" as the factory setting. This setting can be manually switched to the RS232 mode.

This product automatically detects a signal matched in the RS-422/485 mode.

In RS-485 mode, the UNO-3200G series automatically detects the direction of incoming data and switches its transmission direction accordingly. So no handshaking signal (e.g. RTS signal) is necessary. This lets you conveniently build an RS-485 network with just two wires. More importantly, application software previously written for half duplex RS-232 environments can be maintained without modification.

2.2.2 To switch the internal SW1/SW2/SW3 according to the placement

- SW1: COM1 RS232/422/485 mode setting
SW3: COM2 RS232/422/485 mode setting

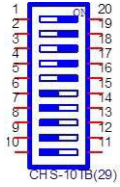
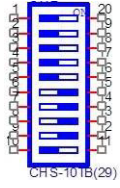
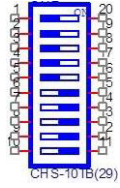
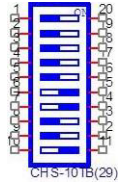
		COM1, COM2 RS232/422/485 mode setting
Description	This switch is used to select COM1, COM2 RS232/422/485 mode setting.	
RS232 Mode	Bit 1,2,3,4,5 ON Bit 6,7,8,9,10 OFF	
RS422 Master Mode	Bit 1,2,3,4,5, 10 OFF Bit 6,7,8,9 ON	
RS422 Slave Mode *	Bit 1,2,3,4,5 OFF Bit 6,7,8,9,10 ON	
RS485 Mode	Bit 1,2,3,4,5,8,9 OFF Bit 6,7,10 ON	

* Factory setting

Figure 2.3 COM setting

- SW2: COM1 RS422 Rx termination (pin1-pin2)

SW2	Description	ON	OFF
Bit 1	Termination resistor select for TX of RS422 Termination resistor select for RS485	Enable	Disable *
Bit 2	Termination resistor select for RX of RS422	Enable	Disable *

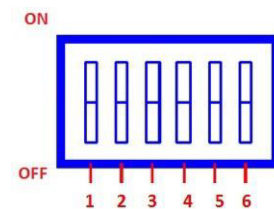

* Factory setting

Figure 2.4 COM1 RS422 Rx termination (pin1-pin2)

- SW2: COM2 RS422 Rx termination (pin3-pin4)

SW2	Description	ON	OFF
Bit 3	Termination resistor select for TX of RS422 Termination resistor select for RS485	Enable	Disable *
Bit 4	Termination resistor select for RX of RS422	Enable	Disable *

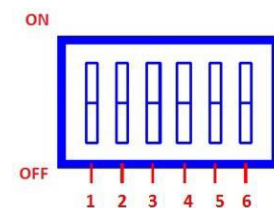

* Factory setting

Figure 2.5 COM2 RS422 Rx termination (pin3-pin4)

2.3 LAN: Ethernet Connector

The product is equipped with two GigabitLAN controllers. The controller chip used is the Intel Ethernet controller with that is fully compliant with 802.1Qav, IEEE1588/802.1AS, 802.3az standards. The Ethernet port provides two standard RJ-45 jacks on the front I/O and LED indicators in front of the connector to show its status of Link (100Mbps orange LED, 1000Mbps green LED) and Active (flashing green LED) status.

2.4 Power Connector

The product supports the external power input via the designated AC adapter for the protection against reverse connection. Therefore, it will not cause any damage to the system by reversed wiring of ground line and power line.

2.5 USB Connector

The USB interface supports Plug and Play, which enables you to connect or disconnect a device, without turning off the computer. This provides six USB connectors, which gives complete Plug & Play and hot swapping for up to 127 external devices. Six connectors are compatible with USB3.0 devices and also USB EHCI, Rev. 2.0 compliant. The USB interface can be disabled in the system BIOS setup.

2.6 Display Connector

The product is equipped with HDMI, DVI-I controller for high-resolution display interface.

Under the factory setting, the display is set as in the table below.

By pressing the Windows Logo key and the P key at the same time, the display can be switched.

When there is no Windows Logo key, prepare a keyboard which includes the Windows Logo.

Display Configuration	VGA (with DVI-VGA Display conversion adapter)		DVI-I		HDMI	
	Use	Display allocation	Use	Display allocation	Use	Display allocation
Single Display	<input type="radio"/>	Display 1 (main display)	-	-	-	-
	-	-	<input type="radio"/>	Display 2 (extended display)	-	-
	-	-	-	-	<input type="radio"/>	Display 2 (extended display)
Dual Display	<input type="radio"/>	Display 1 (main display)	-	-	<input type="radio"/>	Display 2 (extended display)
	-	-	<input type="radio"/>	Display 3 (extended display)	<input type="radio"/>	Display 2 (extended display)

When attaching the HDMI cable, ensure correct cable orientation and attach it along the lower edge of the HDMI port.

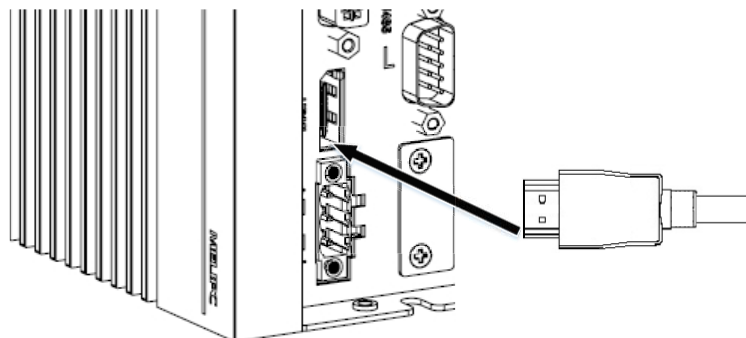

Figure 2.6 HDMI Port

Notes on initialization of Windows

When performing initial setup of Windows at the first boot (including immediately after recovery with recovery media), use a DVI to VGA conversion adapter to connect to a VGA compatible display.

When the display is connected with a display interface other than VGA, the image may not be displayed on the display.

2.7 RTC Battery

The RTC Battery to ensure the setting in BIOS and system clock can be kept, even with power disconnected for a short time.

- Type: BR2032 (Using CR2032 is NOT recommended)
- Output Voltage: 3 VDC

2.8 Power Button/Power Management

Press the "PWR" button to power on or power off (ATX type). This product supports the ACPI (Advanced Configuration and Power Interface). As well as power on/off, it supports multiple suspend modes, such as Suspend to RAM (S3) and Suspend to Disk (S4).

2.8.1 Power mode switch

User can set AT/ATX mode in BIOS setup menu "Chipset ⇒ PCH-IO Configuration ⇒ State After G3".

- [S0 State]: AT mode
- [S5 State]: ATX mode

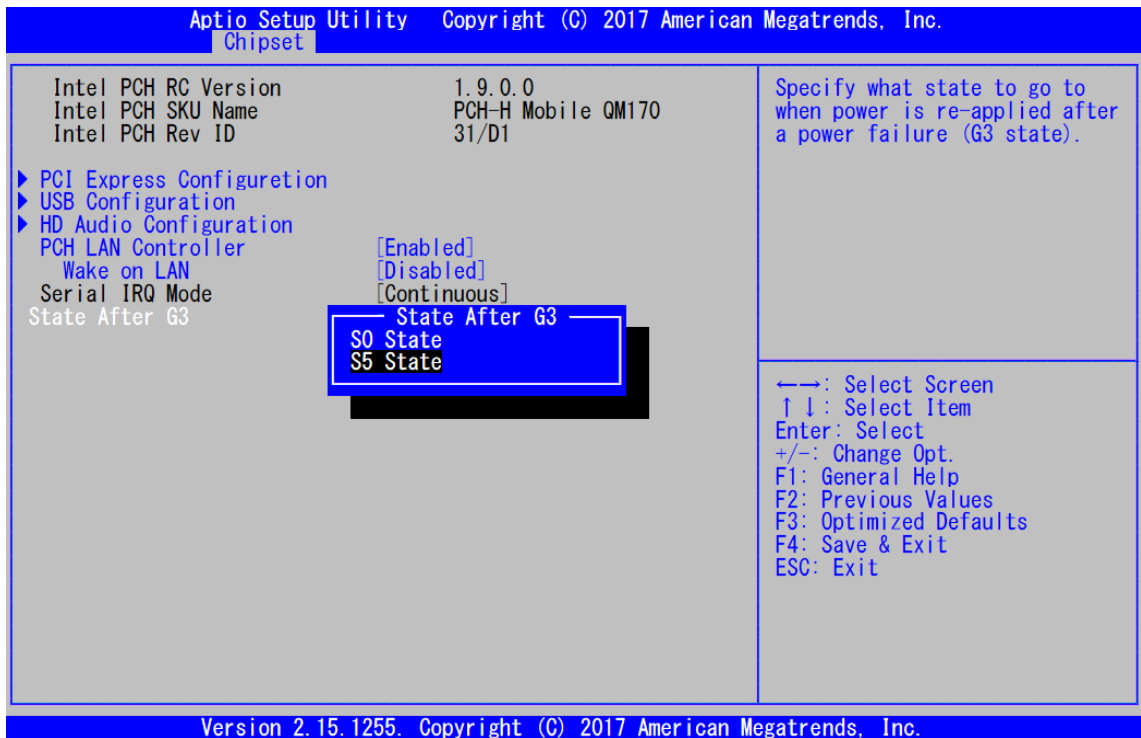

Figure 2.7 AT/ATX Adjustment

2.9 mPCIe Card Socket

There are two sockets for full size PCI Express mini cards. The first interface (CN20) is the default defined for mSATA. The second interface (CN19) mainly targets iDoor technology/module, and various applications including serial port, Profibus, WLAN GPRS, 3G, and MRAM are available.

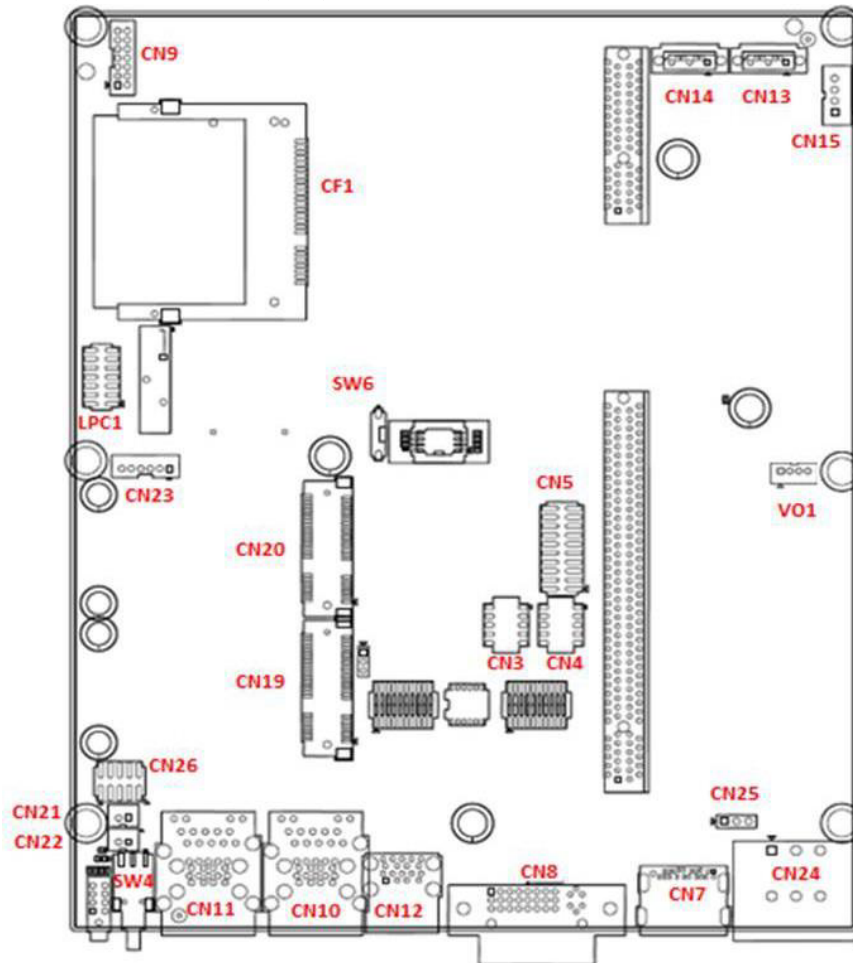

Figure 2.8 mPCIe card sockets placement

2.9.1 iDoor Expansion Slot

At the front side, there's a iDoor Expansion slot for users to install Mini-PCIe modules to extend extra I/O ports for specific applications like Isolation COM, Digital I/O, and CAN modules.

2.10 PCIe/PCI Slot

To satisfy extension requirement, the product is equipped with one PCIe x 16 slot and one PCI slot.

The PCIe slot supports the standard PCIe card compatible with PCIe x 16, PCIe x 8, and PCIe x 4 such as USB extension card and Ethernet extension card.

Note! PCI/PCIe card supports wide temperature range (at least +70°C).



2.11 SATA HDD/SSD Drive

The product is equipped with two 2.5" SATA bays supporting 6Gbps at maximum. The product does not support RAID.

Note! The 2.5" HDD/SSD which is mountable needs to be within 9.5 mm in height. The maximum available supply power is 5 V/700mA.



2.12 Audio Jack

The product is equipped with one Line-out port, one Line-in port, and one MIC. (Pin Header, CN9)

2.13 LED Indicators

There are LEDs to indicate the status of the system.

- PWR (Power) : Green means normal, yellow is stand by.
- HDD : Turns on in green during reading/writing to HDD.
- BTR (Battery) : Red means the battery voltage has been decreased.
- COM1 & COM2 (Tx/Rx) : Flashing green means signals are being transmitted and received.

Chapter 3

Initial Setup

This chapter describes how to set up the hardware.

Sections include:

- Connecting Power
- Inserting an iDoor Module
- Installing a Hard Disk
- Installing an Interface Card or CFast Card
- Mounting MI2012-W
- Battery Replacement
- Troubleshooting

3.1 Connecting Power

Input the product power by using the designated AC adapter supplied.

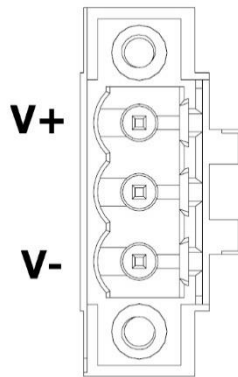
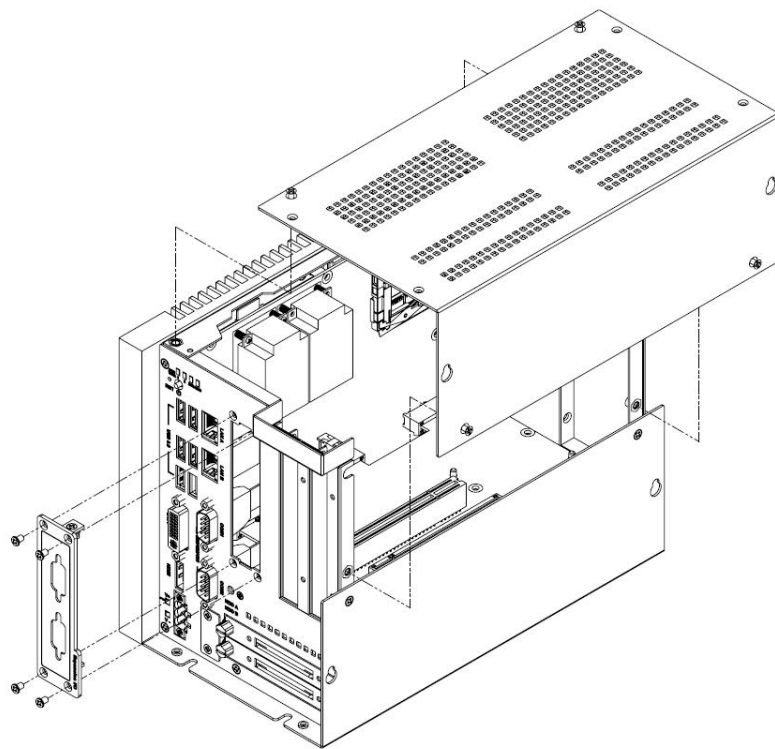

Figure 3.1 Power Connector

3.2 Inserting an iDoor Module

This product has one iDoor for various expansions. Please follow the below diagram to install iDoor modules into the system.

1. Remove the screws from the base plate and lift to remove.



2. Insert & lock the mPCIe card using screws.

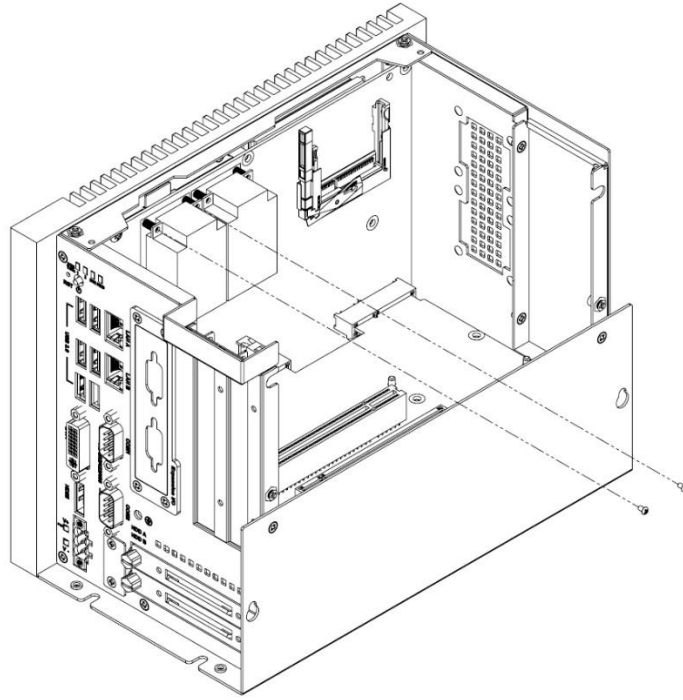

3. Replacing the blanking plate with the iDoor plate.

Note! For iDoor POE and USB 3.0 module, the product is equipped with the internal backup battery (VO1) on the system board.

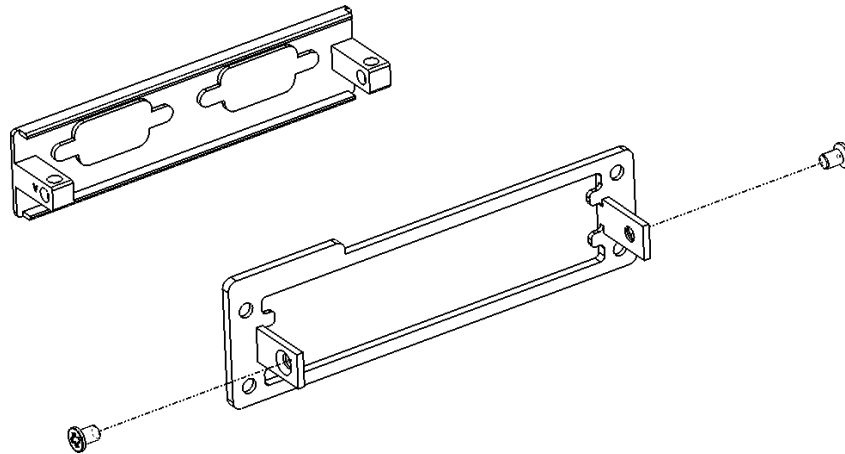

3.3 Installing a Hard Disk

Follow the steps below to install a HDD/SSD into the system.

1. Release thumb screw and pull out the HDD/SSD bracket.

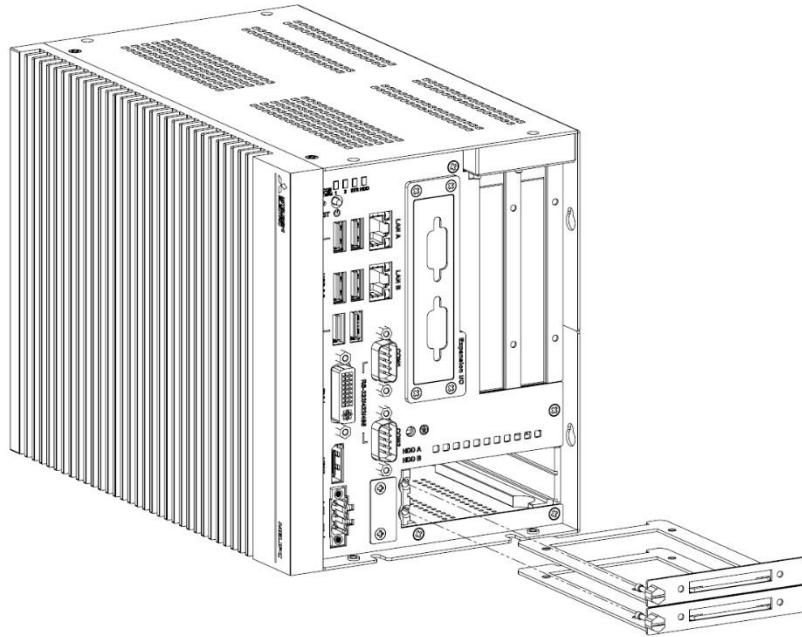

2. Screw the HDD/SSD to the bracket.

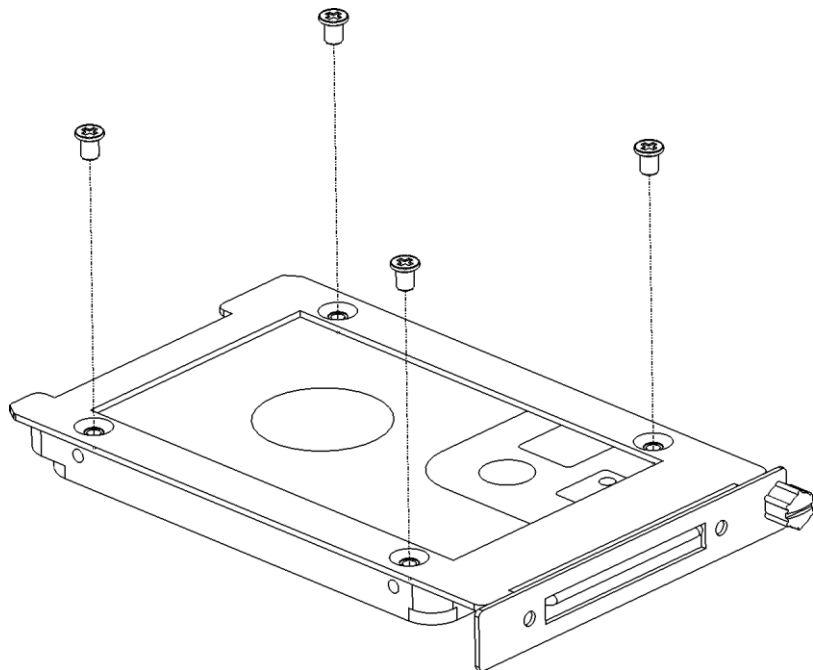

3. Put the bracket back & tighten the thumb screw.

Note! Available 130 mm space upon HDD/SSD bracket.



3.4 Installing an Interface Card or CFast Card

The product is equipped with PCIe/PCI slot as a backplane of options to satisfy various requirements, supporting a variety of interface cards. And the product is equipped with an internal CFast slot for an extension storage.

Follow the exploded diagram to install an interface card or CFast card.

1. Loosen the cover of the chassis.

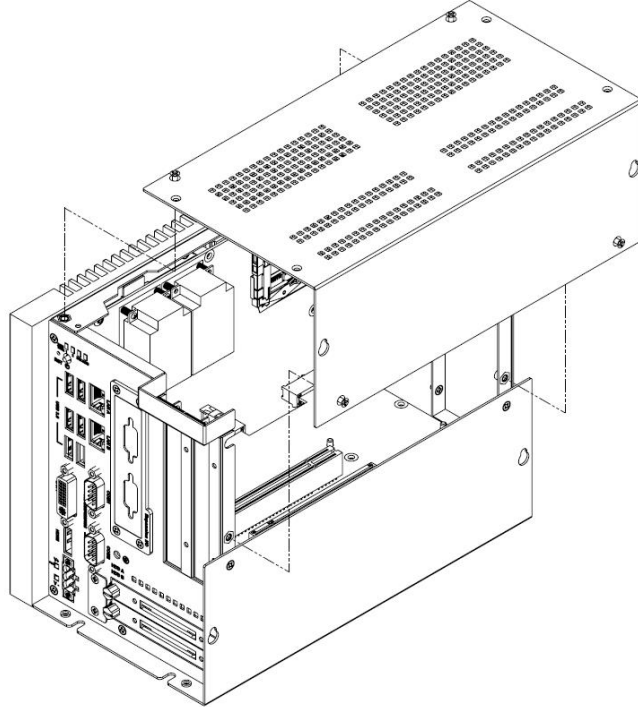

2. Insert your PCI/PCIe card or CFast card and secure it.

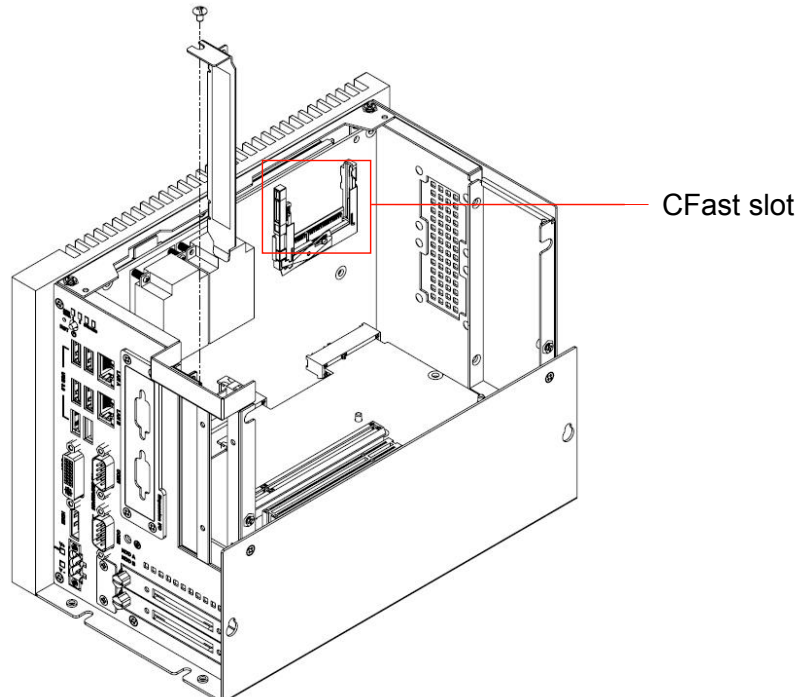

3. Assemble the cover of the chassis.

3.5 Mounting MI2012-W

The product can be installed in three styles: wall-mount, standalone, and installed inside the control panel. All of them can allow easy installation. To secure the wall-mount metal fitting to the product, use a M3 x 5L screw. The mounting screw to secure the product to a wall or a desk should not exceed 4 mm in diameter. The diameter of the screw head should be larger than 6 mm, and smaller than 7 mm.

The product needs to be installed to an environment which satisfies the requirements described in "1.3.2 Environment".

Below separate figures shows the capability of mounting:

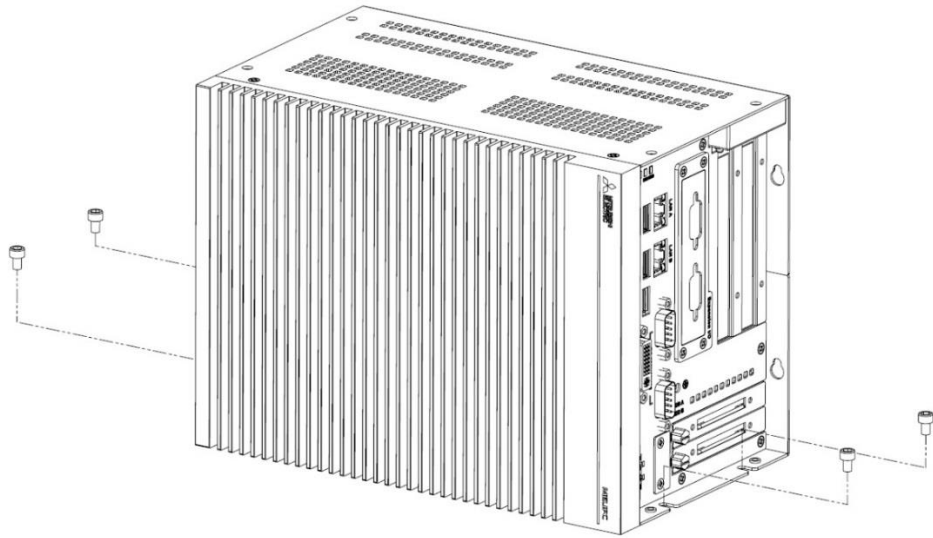

Figure 3.2 Stand Mount

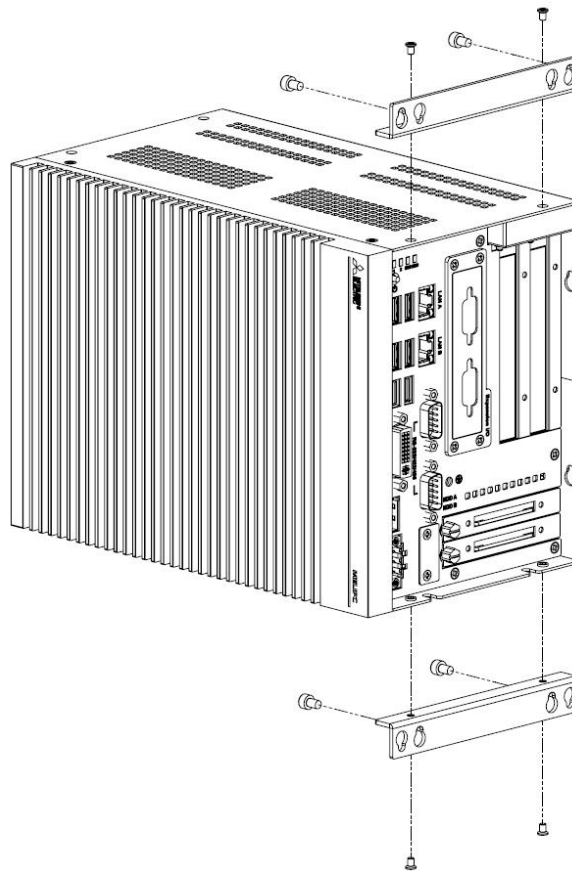

Figure 3.3 Enclosure Mount

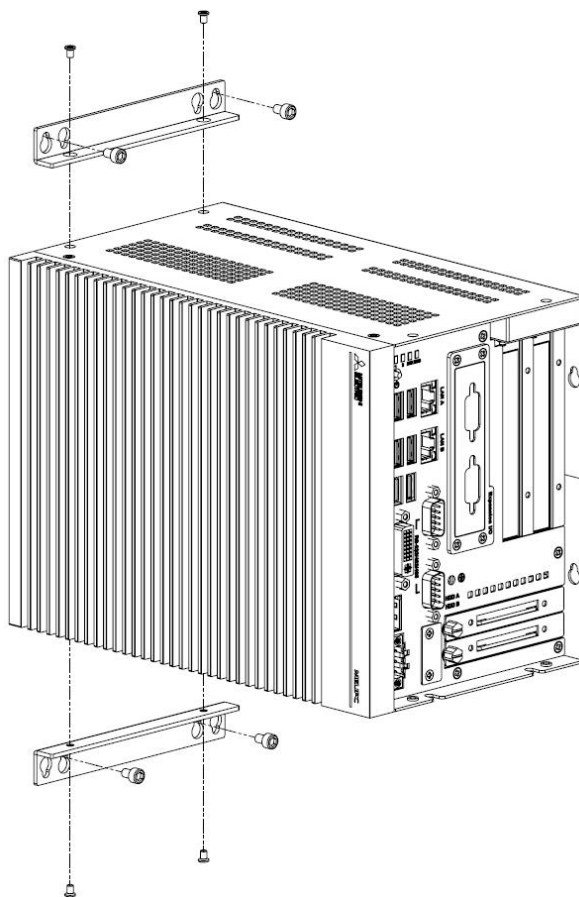

Figure 3.4 Wall Mount (01)

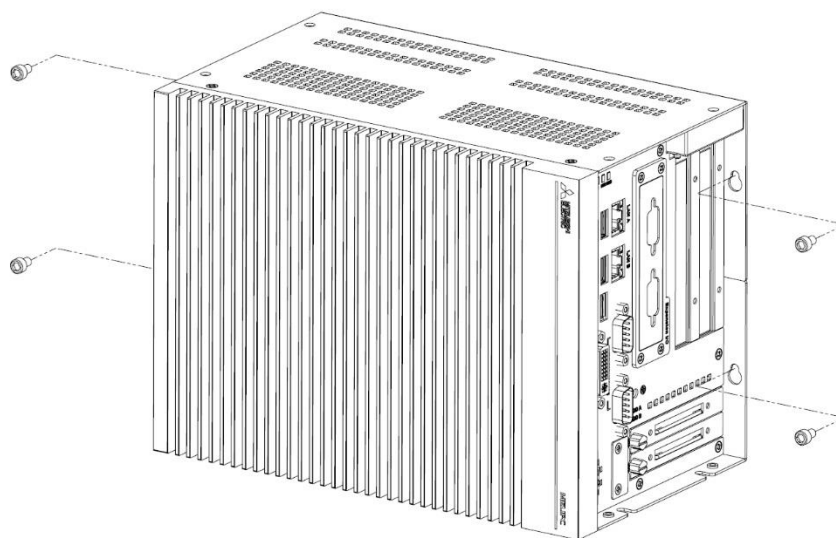
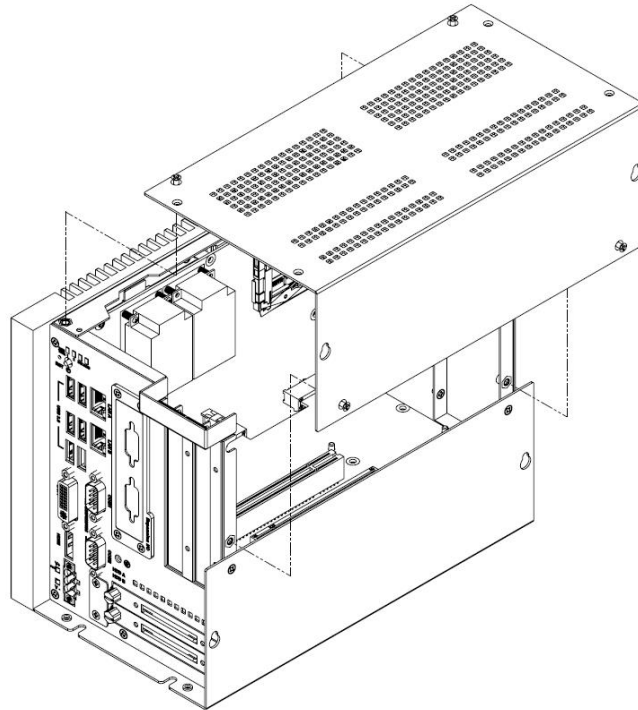

Figure 3.5 Wall Mount (02)

3.6 Battery Replacement

Replace the battery in the following step:

1. Loosen the chassis cover.



2. Remove the battery.
3. Insert a new battery and secure it.

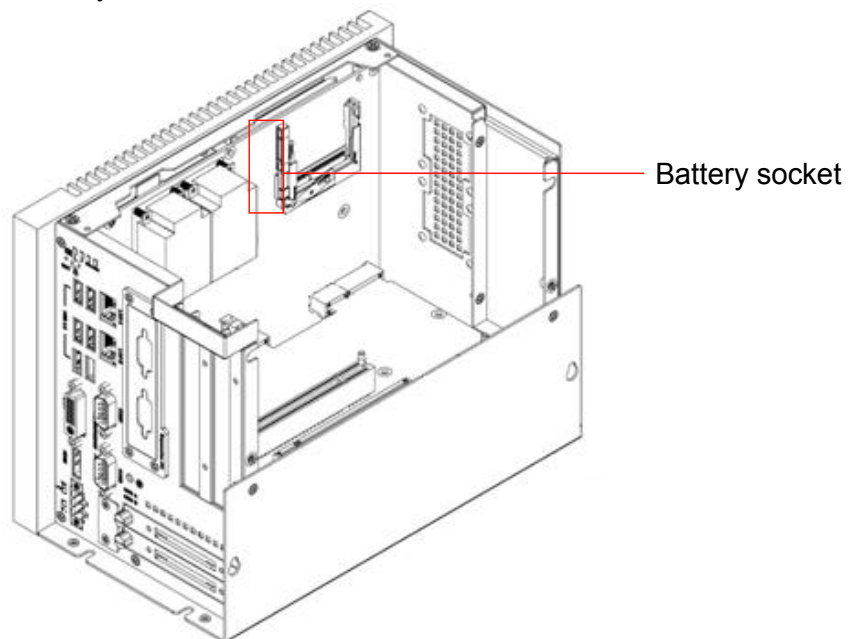

4. Assemble the chassis cover.

Note! Ensure correct battery orientation.
Attach the battery so that the plus side of the battery faces downward.



3.7 Windows update settings

To prevent an automatic restart of the Windows section by an automatic update of Windows Update while this product is in operation (a user is logged into the Windows section), change the following group policy from the Windows default settings.

Group policy	Settings after change
No auto-restart with logged on users for scheduled automatic updates installations	Enabled

3.8 Troubleshooting

When the product does not function as expected, check the product by referring to the following checklist before asking for repair. When there is any item in the list corresponding to the problem, try the action described in the list. If the problem persists, record the message on the display, and contact the sales shop or the maintenance company.

Power does not turn ON

- Is the power cord and the AC adapter correctly connected?

⇒ Check PWR LED on the front.

When PWR LED is in orange, press the power switch to turn ON the power.
When PWR LED is not turned ON, the power cord and the AC adapter may not be correctly connected.

LAN/RS232C/RS485/RS422 communication is not available

- Is the power of the PC turned ON?

⇒ Check PWR LED on the front.

When PWR LED is in orange, press the power switch to turn ON the power.
When PWR LED is not turned ON, the power cord and the AC adapter may not be correctly connected.

- Is the interface cable correctly connected? Is the FG cable correctly connected?

⇒ Each interface cable and FG cable may not be correctly connected.

The display does not show images

- Is the power of the PC turned ON?

⇒ Check PWR LED on the front.

When PWR LED is in orange, press the power switch to turn ON the power.
When PWR LED is not turned ON, the power cord and the AC adapter may not be correctly connected.

- Is the display power turned ON?

⇒ Turn ON the display power.

- Is the interface cable correctly connected?

⇒ The interface cable may not be correctly connected.

- Is the display in use set to the main display?

⇒ Pressing the Windows Logo key and the P key at the same time can switch the display. Refer to "2.6 Display Connector".

When there is no Windows Logo key, prepare a keyboard including the Windows logo.

- Isn't the display connected via HDMI?

⇒ Some interface to connect the display may disable to show image. Try connection with other interface, or replace the display to the one of other manufacturer.

- Did you connect the display with a display interface other than VGA at the first start?
 - ⇒ When performing initial setup of Windows at the first boot (including immediately after recovery with recovery media), use a DVI to VGA conversion adapter to connect to a VGA compatible display. When the display is connected with a display interface other than VGA, the image may not be displayed on the display.

BTR LED turns ON (or flashes)

- Isn't the battery voltage lowered?
 - ⇒ Turn OFF the system power, and replace the battery with the new one by referring to "3.6 Battery Replacement".
- Is the battery correctly attached?
 - ⇒ Turn OFF the system power, and replace the battery with the new one by referring to "3.6 Battery Replacement".
- Isn't there any foreign substance adhered to or around the battery?
 - ⇒ Turn OFF the system power, and check for foreign substance around the battery socket by referring to "3.6 Battery Replacement."

3.9 Cautions when repairing the product

This shows precautions in repairing the product.

- When repairing, software and data installed by the customer on the product may be deleted, and the product may be returned to its default shipping condition. We shall not be held responsible for the loss or damage of content stored within storage devices regardless of faults, damage, theft during transport, or any other reason.
- When requesting repair, please ensure that you back up all data in advance. When a product is received for repair, we will work under the assumption that the data has been backed up.
- When requesting backup overseas, ensure that the following software and data is first deleted.
 - Software subject to export restrictions on its export(encryption software, etc.)
 - Software or data such as confidential company information.
- We assume responsibility for the deletion of the contents of removable media in the repair process. Note that.

Appendix A

System Settings and Pin Assignments

A.1 System I/O Address and Interrupt Assignment

Interrupt#	Interrupt source
NMI	Parity error detected
IRQ0	System timer
IRQ1	Standard 101/102 - Key or Microsoft Natural PS/2 Keyboard
IRQ2	Interrupt from controllers 2 (cascade)
IRQ3	Communications Port (COM2)
IRQ4	Communications Port (COM1)
IRQ5	Available
IRQ6	Available
IRQ7	EC Watch DOG
IRQ8	System CMOS/real time clock
IRQ9	Microsoft ACPI-Compliant system
IRQ10	Available
IRQ11	Available
IRQ12	PS/2 Compatible Mouse
IRQ13	Numeric data processor
IRQ14	Primary IDE
IRQ15	Secondary IDE

A.2 Board Connectors and Switches

There are several connectors and switches on the inside board. The following sections tell you how to configure the hardware setting. Figure A.1 shows the locations of the connectors and switches.

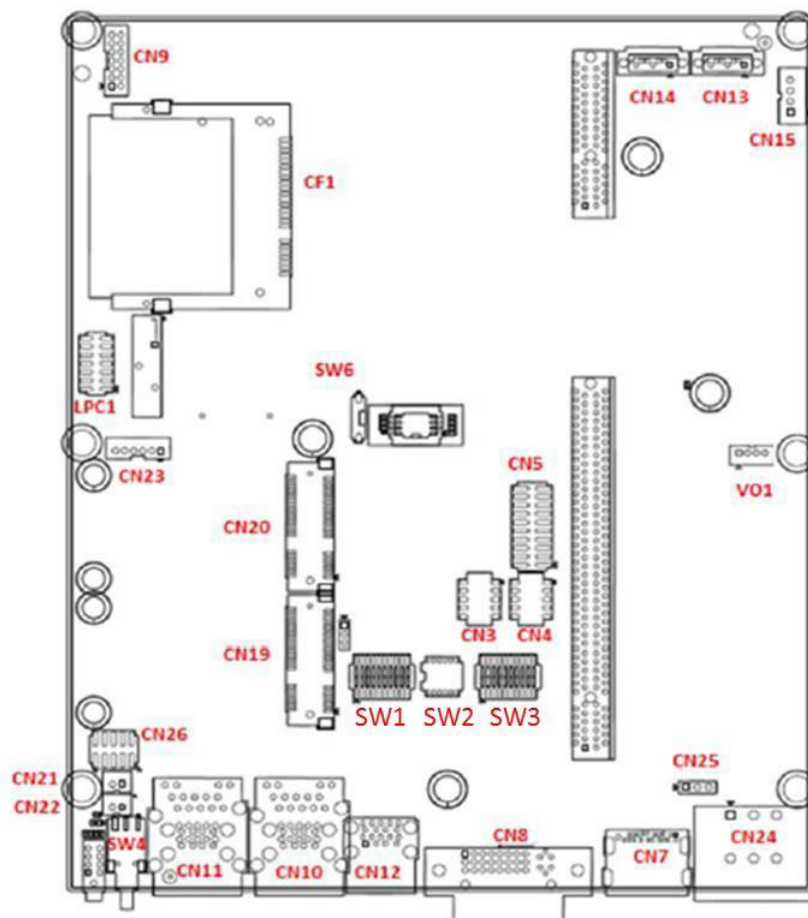

Figure A.1 Bottom view of System Board

A.3 Function of connectors and switches

The connectors and switches on the inside boards are defined as table A.2.

Table A.2: Connectors on System board

Label	Function
SW1	COM1 setting
SW2	RS-422/485 receiver termination
SW3	COM2 setting
SW4	Power Switch
SW5	Reset
CN7	HDMI
CN8	DVI
CN9	Audio
CN10	LAN & 2 x External USB3.0
CN11	LAN & 2 x External USB3.0
CN12	External USB3.0 x 2
CN19	mPCIe
CN20	mPCIe or mSATA
CN24	Power input & Relay

A.4 Audio (Pin header)

Table A.3: CN9 Audio

Pin	Pin Name
1	LOUTR
2	LOUTL
3	LOUT_JD
4	GND
5	LINR
6	LINL
7	LIN_JD
8	GND
9	MIC1R
10	MIC1L
11	MIC1_JD
12	GND
13	GND
14	GND

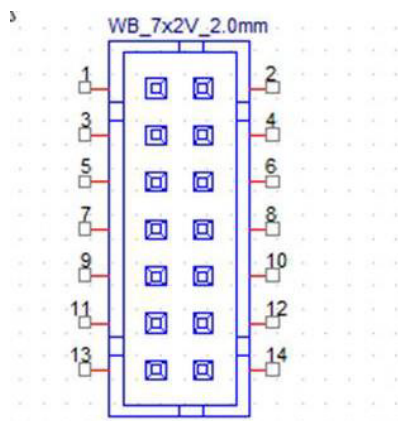

A.5 COM1/COM2

Table A.4: COM port pin assignment

Connector		Function	
Pin	RS232	RS422	RS485
1	DCD	422_TXD	485_Data-
2	RXD	422_TXD+	485_Data+
3	TXD	422_RXD+	
4	DTR	422_RXD-	
5	GND	GND	
6	DSR		
7	RTS		
8	CTS		
9	RIC		

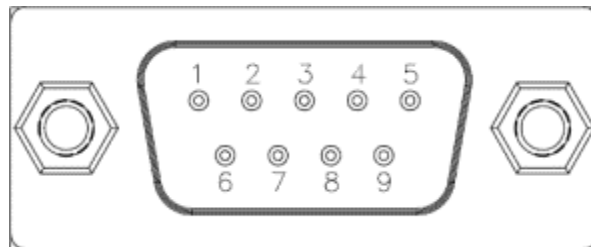

A.6 Power Connector (PWR)

Table A.6: Power connector pin assignments

Pin	Pin Name
1	V+
2	NC
3	V-

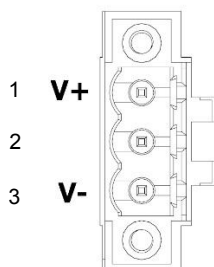

A.7 SW4 Power Switch

Table A.7: SW4 Power Switch

Pin	Pin Name
1	NC
2	GND
3	PSIN
4	NC
5	NC
6	NC
7	NC

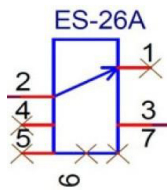

A.8 CN19/CN20 mPCIe

Table A.8: CN19 / CN20 mPCIe

Pin	Pin Name
1	WAKE#
2	+3.3VSB
3	NC
4	GND
5	NC
6	+1.5V
7	NC
8	UIM_PWR
9	GND
10	UIM_DATA
11	REFCLK-
12	UIM_CLK
13	REFCLK+
14	UIM_RESET
15	GND
16	UIM_VPP
17	NC
18	GND
19	NC
20	PU3.3_AUX
21	GND
22	PERST#
23	PERn0
24	+3.3VSB
25	PERp0
26	GND
27	GND
28	+1.5V
29	GND
30	SMB_CLK
31	PETn0
32	SMB_DAT
33	PETp0
34	GND
35	GND
36	USB D-
37	GND
38	USB D+
39	+3.3VSB
40	GND
41	+3.3VSB
42	NC
43	GND

Table A.8: CN19/CN20 mPCIe

44	NC
45	NC
46	NC
47	NC
48	+1.5V
49	NC
50	GND
51	NC
52	+3.3VSB

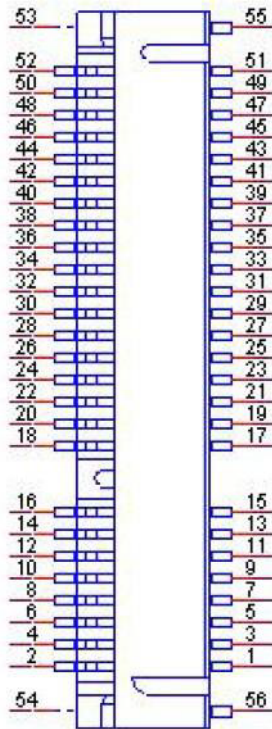

A.9 CN20 mSATA

Table A.9: CN20 mSATA

Pin	Pin Name
1	WAKE#
2	+3.3VSB
3	NC
4	GND
5	NC
6	+1.5V
7	NC
8	UIM_PWR
9	GND
10	UIM_DATA
11	REFCLK-
12	UIM_CLK
13	REFCLK+
14	UIM_RESET
15	GND
16	UIM_VPP
17	NC
18	GND
19	NC
20	PU3.3AUX
21	GND
22	PERST#
23	SATA_RX+
24	+3.3VSB
25	SATA_RX-
26	GND
27	GND
28	+1.5V
29	GND
30	SMB_CLK
31	SATA_TX-
32	SMB_DAT
33	SATA_TX+
34	GND
35	GND
36	USB D-
37	GND
38	USB D+
39	+3.3VSB
40	GND
41	+3.3VSB
42	NC
43	GND

Table A.9: CN20 mSATA

44	NC
45	NC
46	NC
47	NC
48	+1.5V
49	NC
50	GND
51	NC
52	+3.3VSB

A.10 VO1 reserved for power output

Table A.10: VO1 reserved for power output

Pin	Pin Name
1	VIN
2	VIN
3	GND
4	GND

Note! This connector support max 2 A.

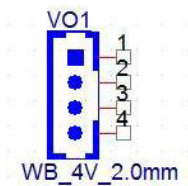

A.11 CN1 internal power supply 12V for PCI/PCIe

This connector support 12V(3A).

Table A.11: CN1 internal power supply 12V for PCI/PCIe

Pin	Pin Name
1	GND
2	GND
3	12V
4	12V

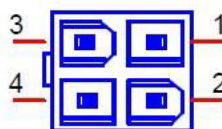
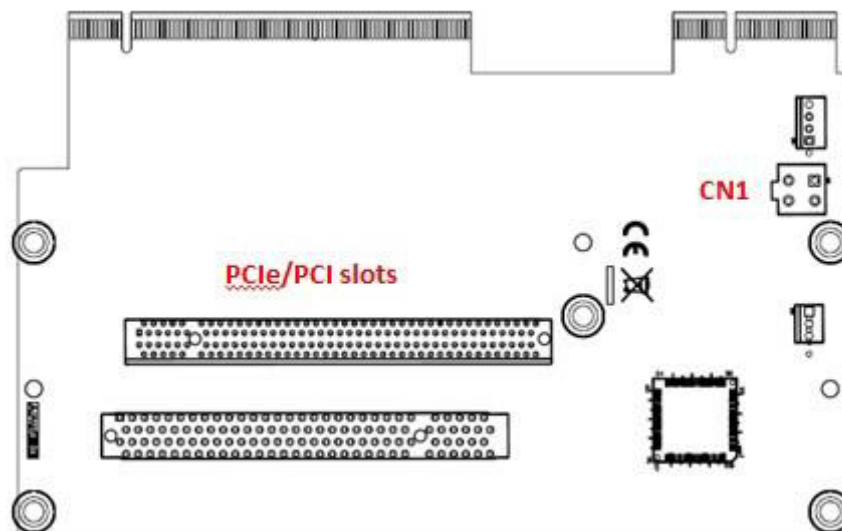

Appendix B

Recovery

B.1 Creating Recovery Media

This product incorporates the image file (recovery.iso) to create the recovery media in the following folder:

C:\Recovery_Media

By using the recovery media, the system can be restored to the initial state. The recovery media should be preliminarily created by using a writing software.

[Precautions]

- Provide a blank media which capacity is that of the one-sided two-layered DVD (8.5 GB) or more.
- The recovery with the recovery media does not restore the ISO image to create the recovery media. Store the recovery media securely.
- Remove any storage device added such as CFast card or 2.5" HDD/SSD before recovery. If these devices are not removed before recovery, the data inside the card may be lost.
- Do not connect any external storage device to the USB port other than the USB DVD drive to which the recovery media is set.

B.2 BIOS Setting Change

1. Set the recovery media to the USB DVD drive, and connect it with the USB port.
2. Turn ON the PC power.
3. Press down the key during the POST screen is displayed, to start up the BIOS Setup Utility.
4. Move to [Boot], and select [Boot Option #1] with the <Enter> key.
5. Select [UEFI: (USB DVD drive name)] with the <Enter> key.
6. Return to [Boot] with the <Enter> key, and move to [Save & Exit].
7. Select [Save Changes and Reset] with the <Enter> key, and the confirmation message appears.
Select [Yes].

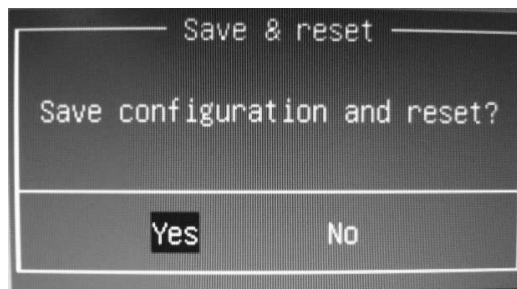

B.3 Recovery

1. Start up from the recovery media.
When the message "Press any key to boot from CD or DVD..." appears, press the <Enter> key to start up from the recovery media.
2. Command prompt opens, and the following message appears:
CAUTION: All the data on the disk will be DELETED.
Erase all data and continue? (Y or N):
Press the <Y> key.
Pressing the <N> key at this time cancels the process.
The installation takes approximately 30 to 40 minutes.
3. When the recovery completes, the PC power is automatically turned OFF.
4. Press the Power switch of the PC to turn ON the power.

B.4 Pre-installation Software

When the Edgecross basic software and SLM data collector is uninstalled by mistake, re-installation is possible by using the installation file stored in the following folder:

Edgecross basic software:	C:\MELIPC\BasicSoftware
SLMP data collector:	C:\MELIPC\DataCollector\SLMP

When these installation files are deleted by mistake, recover them by using the recovery media.

Appendix C

Regulation and Standard

C.1 RoHS information

設備名稱/ Equipment name		電腦/ Embedded Automation Computer				
型號 (型式) / Type designation (Type)		MI2012-W、MI2012-W-CL				
單元 Unit	限用物質及其化學符號 Restricted substances and its chemical symbols					
	鉛 Lead (Pb)	汞 Mercury (Hg)	鎘 Cadmium (Cd)	六價鉻 Hexavalent Chromium (Cr ⁺⁶)	多溴聯苯 Polybrominated biphenyls (PBB)	多溴二苯醚 Polybrominated diphenyl ethers (PBDE)
電路板	—	○	○	○	○	○
機殼 (外殼、支架 … 等)	○	○	○	○	○	○
其它固定組件 (螺絲)	—	○	○	○	○	○
配件 (線材)	—	○	○	○	○	○
記憶卡	—	○	○	○	○	○
存取裝置 (HDD)	—	○	○	○	○	○
分離式 電源線組	○	○	○	○	○	○
電源供應器	—	○	○	○	○	○
<p>備考1.“超出0.1 wt %”及“超出0.01 wt %”係指限用物質之百分比含量超出百分比含量基準值。 Note 1. “Exceeding 0.1 wt %” and “exceeding 0.01 wt %” indicate that the percentage content of the restricted substance exceeds the reference percentage value of presence condition.</p> <p>備考2.“○”係指該項限用物質之百分比含量未超出百分比含量基準值。 Note 2. “○”indicates that the percentage content of the restricted substance does not exceed the percentage of reference value of presence.</p> <p>備考3.“—”係指該項限用物質為排除項目。 Note 3. The “—” indicates that the restricted substance corresponds to the exemption.</p>						



廢電池請回收

C.2 EMC AND LOW VOLTAGE DIRECTIVES

Compliance with the EMC Directive, which is one of the EU directives, has been mandatory for products sold within EU member states since 1996 as well as compliance with the Low Voltage Directive since 1997.

For products compliant to the EMC and Low Voltage Directives, their manufacturers are required to declare compliance and affix the CE marking.

The sales representative in EU member states is:

Company: MITSUBISHI ELECTRIC EUROPE B.V.

Address: Mitsubishi-Electric-Platz 1, 40882 Ratingen, Germany

Measures to Comply with the EMC Directive

The EMC Directive sets requirements for emission (conducted and radiated electromagnetic interference emitted by a product) and immunity (the ability of a product not to be influenced by externally generated electromagnetic interference).

This product complies with the EMC Directive related standards as follows.

The manufacturer of the machinery must determine the testing method for compliance and declare conformity to the EMC Directive.

EMC Directive related standards

Item	Standards
Emission	EN 55011:2009+A1:2010 (Group 1, Class A) EN 55032: 2015 + AC: 2016 (Class A) EN 61000-6-4:2007 +A1:2011
Immunity	EN 55024:2010+A1:2015 EN 61000-6-2:2005+AC:2005

Measures to Comply with the Low Voltage Directive

The Low Voltage Directive requires electrical equipment that is designed or adapted for use between 50 to 1000VAC or 75 to 1500VDC to satisfy the safety requirements.

This section describes the precautions for use of this product to comply with the Low Voltage Directive.

These precautions are based on the requirements of the Low Voltage Directive and the harmonized standards. However, they do not guarantee that the entire machinery constructed according to the descriptions complies with the Low Voltage Directive.

The manufacturer of the machinery must determine the testing method for compliance and declare conformity to the Low Voltage Directive.

Standard applied to this product

EN60950-1 "Information technology equipment Safety General requirement"

Compliant range of this product

■ AC adapter

AC adapter have hazardous voltage (peak voltage higher than or equal to 42.4V) internally.

Therefore, insulation between the primary and secondary circuits is reinforced for CE-marked power supply modules.

■ Main unit

It is not targeted for the Low Voltage Directive compliance because the circuits in the product operate at the 24VDC or less rated voltage.

Power supply

AC adapter is designed to meet the overvoltage category II.

Confirm that the power supply to this product meets the overvoltage category II.

Installation site

■ Protection against electric shock

In order to protect a person who does not have adequate knowledge of electrical installation from an electric shock, take the following measures.

- Restrict access to the installation site so that only persons who are trained and has acquired enough knowledge of electrical installation can operate.
- Place on the protective structure with a protection degree of IP20 or higher; control panels for example.

■ Protection from dust and water

Insufficient dustproof and waterproof lower the dielectric withstand of the install site, possibly causing dielectric breakdown.

The insulation of Mitsubishi programmable controllers is designed to be used in an environment of pollution degree 2.

Use them in an environment of pollution degree 2 or below.

Grounding

Securely ground by using the chassis grounding screw on the front panel.

External wiring

■ External devices

For external devices connected to a programmable controller, use the one of which insulation between the interface circuit section to the programmable controller and the hazardous voltage circuit section is reinforced (if the device internally has a hazardous voltage circuit section).

■ Reinforced insulation

Reinforced insulation means an insulation having the following withstand voltage.

Rated voltage of hazardous voltage	Surge withstand voltage (1.2/50 μ s)
150VAC or less	2500V
300VAC or less	4000V

(Overvoltage category II, source: IEC 664)

C.3 Handling of Batteries and Devices with Built-In Batteries in EU Member States

This section describes the precautions for disposing of waste batteries in EU member states and exporting batteries and/or devices with built-in batteries to EU member states.

Disposal precautions

In EU member states, there is a separate collection system for waste batteries. Dispose of batteries properly at the local community waste collection/recycling center.

The following symbol mark is printed on the batteries and packaging of devices with built-in batteries. The symbol mark indicates that batteries need to be disposed of separately from other wastes.



This symbol mark is for EU member states only. The symbol mark is specified in the EU Battery Directive (2006/66/EC) Article 20 "Information for end-users" and Annex II.

Exportation precautions

The EU Battery Directive (2006/66/EC) requires the following when marketing or exporting batteries and/or devices with built-in batteries to EU member states.

- To print the symbol mark on batteries, devices, or their packaging
- To explain the symbol mark in the manuals of the products

■ Labeling

To market or export batteries and/or devices with built-in batteries, which have no symbol mark, to EU member states, print the symbol mark shown in the following on the batteries, devices, or their packaging.

■ Explaining the symbol in the manuals

To export devices incorporating this product to EU member states, provide this manual to the end user. If manuals are not provided, separately attach an explanatory note regarding the symbol mark to each manual of the devices.

C.4 Precautions for Battery Transportation

When transporting lithium batteries, follow the transportation regulations.
For details on the regulations, refer to Mitsubishi Technical Bulletins as follows.

- Precautions for transport regulations on lithium batteries (FA-A-0259)

Regulated models

The battery for this product is classified as shown below.

Model	Supply status	Lithium content	Weight	Classification for transportation
BR2032	Lithium metal battery	0.06 g per unit	2.5 g per unit	Non-dangerous goods

Transport guidelines

Products are packed in compliance with the transportation regulations prior to shipment. When repacking any of the unpacked products for transportation, make sure to observe the IATA Dangerous Goods Regulations, IMDG (International Maritime Dangerous Goods) Code, and other local transportation regulations.
For details, please consult the shipping carrier used.

Perchlorate Regulation in the State of California, USA

California law requires that warning text be displayed on packaging for products incorporating lithium primary batteries containing more than 6 ppb of perchlorate. However, the battery for this product does not contain perchlorate. Therefore, the customer will not be required for any special measure.

C.5 Statement for electromagnetic Interference

VCCI

この装置は、クラスA機器です。この装置を住宅環境で使用すると電波妨害を引き起こすことがあります。この場合には使用者が適切な対策を講ずるよう要求されることがあります。

VCCI - A

Federal Communications Commission (FCC) Statement

This equipment has been tested and complies with the limits for a Class A digital device, pursuant to Part 15 of the FCC Rules. These limits are designed to provide reasonable protection against harmful interference when the equipment is operated in a commercial environment.

This equipment generates, uses, and can radiate radio frequency energy and, if not installed and used in accordance with the instruction manual, may cause harmful interference to radio communications.

Operation of this equipment in a residential area is likely to cause harmful interference, in which case the user will be required to correct the interference at his own expense.

WARNING TO USER

Unauthorized changes or modifications could void the user's authority to operate the equipment.

Properly shielded and grounded cables and connectors must be used in order to meet FCC emission limits. Mitsubishi Electric is not responsible for any radio or television interference caused by using other than recommended cables and connectors or by unauthorized changes or modifications to this equipment.

Industry Canada Statement

This Class A digital apparatus complies with Canadian ICES-003.

Cet appareil numérique de la classe A est conforme à la norme NMB-003 du Canada.

CE Statement

This is a Class A product. In domestic environment this product may cause radio interference in which case the user may be required to take adequate measures.

KC Statement

기종별	사용자안내문
A 급 기기	이 기기는 업무용(A 급)으로 전자파적합등록을 한 기기이오니 판매자 또는 사용자는 이 점을 주의하시기 바라며, 가정외의 지역에서 사용하는 것을 목적으로 합니다.

WARRANTY

Please confirm the following product warranty details before using this product.

1. Gratis Warranty Term and Gratis Warranty Range

If any faults or defects (hereinafter "Failure") found to be the responsibility of Mitsubishi occurs during use of the product within the gratis warranty term, the product shall be repaired at no cost via the sales representative or Mitsubishi Service Company.

However, if repairs are required onsite at domestic or overseas location, expenses to send an engineer will be solely at the customer's discretion. Mitsubishi shall not be held responsible for any re-commissioning, maintenance, or testing on-site that involves replacement of the failed module.

[Gratis Warranty Term]

The gratis warranty term of the product shall be for one year after the date of purchase or delivery to a designated place. Note that after manufacture and shipment from Mitsubishi, the maximum distribution period shall be six (6) months, and the longest gratis warranty term after manufacturing shall be eighteen (24) months. The gratis warranty term of repair parts shall not exceed the gratis warranty term before repairs.

[Gratis Warranty Range]

(1).The range shall be limited to normal use within the usage state, usage methods and usage environment, etc., which follow the conditions and precautions, etc., given in the instruction manual, user's manual and caution labels on the product.

(2).Even within the gratis warranty term, repairs shall be charged for in the following cases.

1. Failure occurring from inappropriate storage or handling, carelessness or negligence by the user.
Failure caused by the user's hardware or software design.
2. Failure caused by unapproved modifications, etc., to the product by the user.
3. When the Mitsubishi product is assembled into a user's device, Failure that could have been avoided if functions or structures, judged as necessary in the legal safety measures the user's device is subject to or as necessary by industry standards, had been provided.
4. Failure that could have been avoided if consumable parts (battery, backlight, fuse, etc.) designated in the instruction manual had been correctly serviced or replaced.
5. Failure caused by external irresistible forces such as fires or abnormal voltages,
and Failure caused by force majeure such as earthquakes, lightning, wind and water damage.
6. Failure caused by reasons unpredictable by scientific technology standards at time of shipment from Mitsubishi.
7. Any other failure found not to be the responsibility of Mitsubishi or that admitted not to be so by the user.

2. Onerous repair term after discontinuation of production

(1).Mitsubishi shall accept onerous product repairs for five (5) years after production of the product is discontinued. Discontinuation of production shall be notified with Mitsubishi Technical Bulletins, etc.

(2).Product supply (including repair parts) is not available after production is discontinued.

3. Overseas service

Overseas, repairs shall be accepted by Mitsubishi's local overseas FA Center.

Note that the repair conditions at each FA Center may differ.

4. Exclusion of loss in opportunity and secondary loss from warranty liability

Regardless of the gratis warranty term, Mitsubishi shall not be liable for compensation to:

- (1). Damages caused by any cause found not to be the responsibility of Mitsubishi.
- (2). Loss in opportunity, lost profits incurred to the user by Failures of Mitsubishi products.
- (3). Special damages and secondary damages whether foreseeable or not, compensation for accidents, and compensation for damages to products other than Mitsubishi products.
- (4). Replacement by the user, maintenance of on-site equipment, start-up test run and other tasks.

5. Changes in product specifications

The specifications given in the catalogs, manuals or technical documents are subject to change without prior notice.

REVISIONS

The manual number is given on the bottom left of the back cover.

Revision date	Manual number	Description
July, 2018	SH-081994ENG-A	First edition
Jan, 2019	SH-081994ENG-B	■ Added model MI2012-W-CL ■ Added or modified parts Precautions regarding Warranty, Safety Precautions, Contents, Section 1.1, 1.2.1, 1.3, 1.5 Appendix A.6, C.1, C.2
Apr, 2019	SH-081994ENG-C	■ Added or modified parts Section 2.6, 2.8.1, 3.8

This manual confers no industrial property rights or any rights of any other kind, nor does it confer any patent licenses. Mitsubishi Electric Corporation cannot be held responsible for any problems involving industrial property rights which may occur as a result of using the contents noted in this manual.

© 2018 MITSUBISHI ELECTRIC CORPORATION

TRADEMARKS

Ethernet is a registered trademark of Fuji Xerox Co., Ltd. in Japan.

The terms HDMI and HDMI High-Definition Multimedia Interface, and the HDMI Logo are trademarks or registered trademarks of HDMI Licensing Administrator, Inc. in the United States and other countries.

Intel, and Intel Core are either registered trademarks or trademarks of Intel Corporation in the United States and/or other countries.

Microsoft, and Windows are either registered trademarks or trademarks of Microsoft Corporation in the United States and/or other countries.

The company names, system names and product names mentioned in this manual are either registered trademarks or trademarks of their respective companies.

In some cases, trademark symbols such as "™" or "®" are not specified in this manual.

SH(NA)-081994ENG-C(1904)

MODEL:MELIPC-MI2012-U-E

mitsubishi electric corporation

HEAD OFFICE : TOKYO BUILDING, 2-7-3 MARUNOUCHI, CHIYODA-KU, TOKYO 100-8310, JAPAN
NAGOYA WORKS : 1-14, YADA-MINAMI 5-CHOME, HIGASHI-KU, NAGOYA, JAPAN

When exported from Japan, this manual does not require application to the
Ministry of Economy, Trade and Industry for service transaction permission.

Specifications subject to change without notice.